

**FEATURES**

- 100 mm<sup>2</sup> Square Active Area
- Responsivity @ 13.5 nm 0.09 A/W
- Detection Range 12 nm to 18 nm
- Shipped with Protective Cover

**Electro-Optical Characteristics at 25°C**

Parameters	Test Conditions	Min	Typ	Max	Units
Active Area	10 mm x 10 mm		100		mm <sup>2</sup>
Responsivity	@ 13.5 nm	0.08	0.09	0.1	A/W
Dark Current	V <sub>R</sub> = 15 V		8	25	nA
Reverse Breakdown Voltage, V <sub>R</sub>	I <sub>R</sub> = 1 μA	25			Volts
Capacitance, C	V <sub>R</sub> = 0 V	0.8	1	1.2	nF
Capacitance, C	V <sub>R</sub> = 12 V	220	260	350	pF
Response Time, tr	RL = 50 Ω, V <sub>R</sub> = 12 V		30		nsec

**Thermal Parameters**

Storage and Operating Temperature Range	Units
Ambient	-10° to 40°C
Nitrogen or Vacuum	-20 to 80°C
Lead Soldering Temperature*	260°C

\*0.080" from case for 10 seconds.

**Typical Responsivity at 25°C**

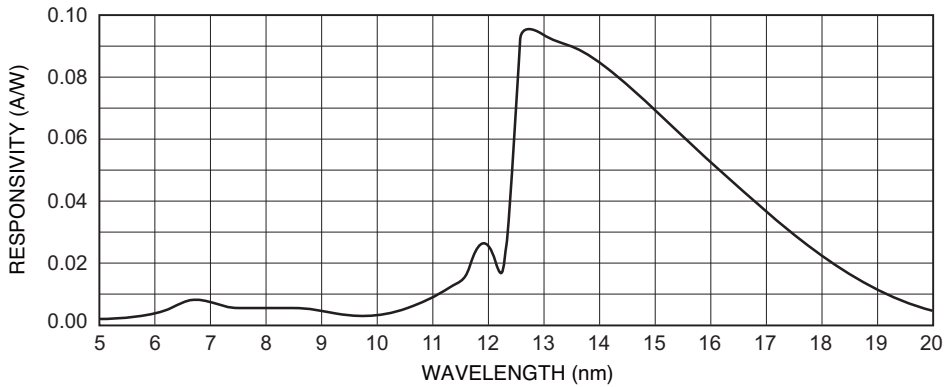

**Package Information**

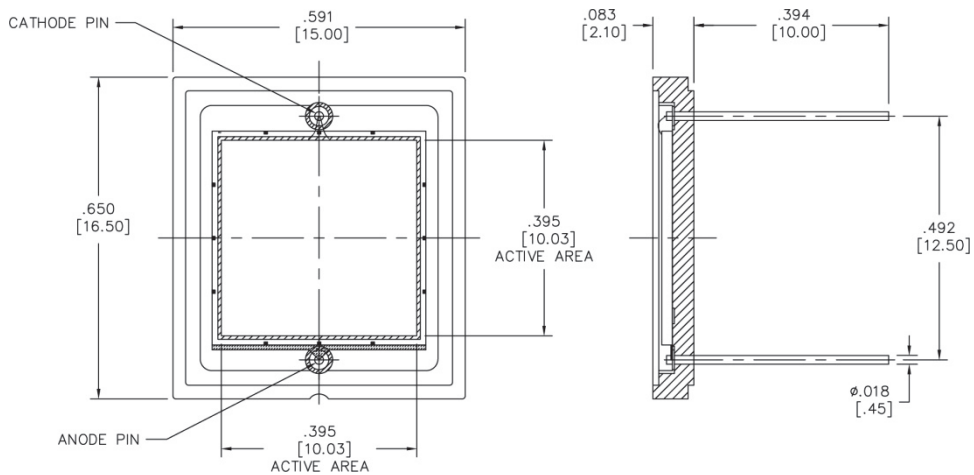

Dimensions are in inch [metric] units.

Specifications are subject to change without prior notice.